

LID

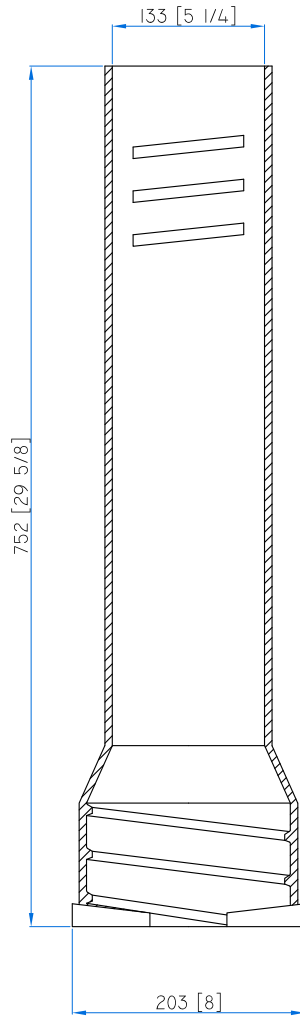

BOTTOM

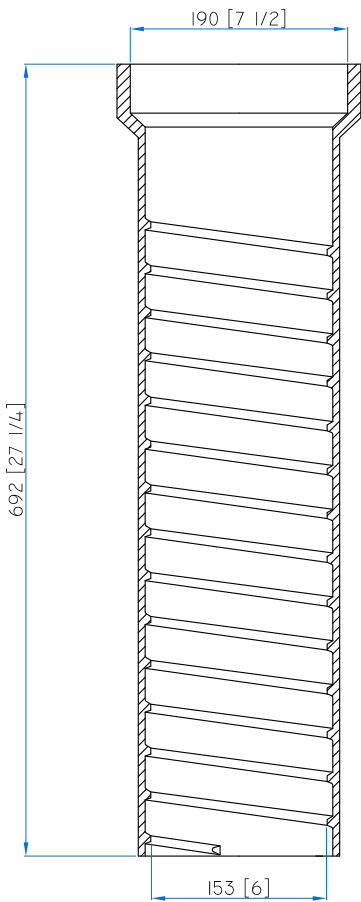

UPPER

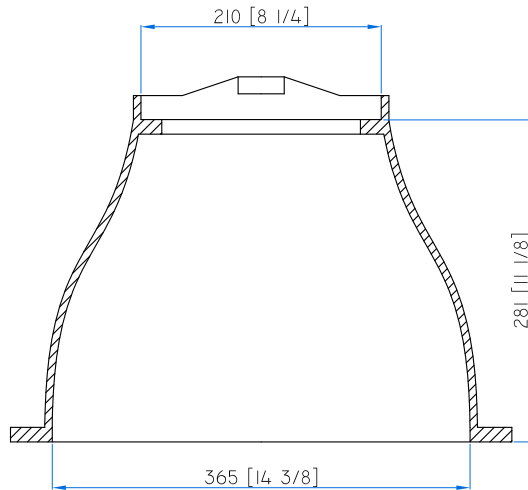

NO 6 BASE



REVISION

DATE

SIGN

ALL DIMENSIONS ARE IN MM

SCALE : N.T.S.

REV.[0] : AS PER BUYER'S DRAWING

MATERIAL : GREY CAST IRON

REV.[1] :

GRADE : A48 CLASS 30B

REV.[2] :

COATING : AS REQUIRED

REV.[3] :

LOADING :

REV.[4] :

WEIGHT : LID-17 (LBS) ; NO 6 BASE-43 (LBS) ; UPPER-58 (LBS) ; BOTTOM-36 (LBS)

DRAWN BY :

CHECKED BY :

APPROVED BY :



DomCast Components & Assemblies,
CANADA

ITEM DESCRIPTION :
5-1/4" SCREW TYPE VALVE BOX

DRAWING NO :
5-1/4 " SCREW TYPE